

PK-232/DSP MULTI-MODE CONTROLLER OPERATION

Welcome to the world of Digital Signal Processing. You may be acquainted with DSP in your new radio, or you may have a Timewave Technology DSP unit in your shack. Now you have DSP capability for your PK-232 digital modes. Here are the most frequently Asked Questions (FAQ's) we have been getting.

What exactly have I bought? The DSP board you have installed provides a proven set of DSP Brick Wall data filters to your PK-232MBX. These are:

- 45 Baud Baudot Twin Peak filter for RTTY
- 100/200 CW filters (Jumper selected, Shipped with jumper on, set at 200)
- 100/200 Adaptive PACTOR filters
- 100 Baud AMTOR/NAVTEXT
- 300 Baud HF Packet
- 1200 Baud UHF/VHF Packet
- European/American Tone Set (Jumper selected, Shipped with jumper off, American Tones)
- WEFAX
- SIAM

Can I use my existing software? In a word, YES. The new firmware provides all the control necessary to select the proper filter, even switching between 100 and 200 baud PacTOR filters as the PK-232/DSP changes the baud rate to accommodate changes in the transmission path.

What should I expect from the new board? DSP provides sharper skirts that reduce the noise in the band pass as well as rejecting interference from adjacent signals. In RTTY this can improve error rates up to 100 times in weak signal and noisy environments. Tune slowly, signals will appear to just pop out of the noise. We suggest you start with a fairly wide filter setting in your radio and cascade that with the narrower filter of the Multi-Mode Controller.

What else has changed? The small red LED on the board will light when a signal overloads the DSP input (Note that a remote light can be tied to Jumper next to the overload LED). The startup sequence is also new, notice that an extra set of lights blink during startup. This tells you the version 7.2 firmware is installed.

Timewave Technology

Visit our web page: <http://www.timewave.com>

Timewave Technology Inc.
501 W. Lawson Ave.
St. Paul, MN 55117 USA

651-489-5080
FAX 651-489-5066
sales@timewave.com

PK-232 MBX EPROM Installation Instructions

Congratulations on the purchase of Timewave's latest firmware for the PK-232 MBX or DSP. We know you will want to get up and running with your new upgrade as quickly as possible so please follow these instructions to install your new firmware EPROMs.

Tools Needed:

A medium Phillips-head screwdriver and a small straight-blade screwdriver.

Step 1:

Turn off the PK-232 and unplug all interconnecting cables from its rear panel.

Step 2:

Prepare a work area that is as static-free as possible before opening the PK-232 MBX. Your work area should not have carpet on the floor, and if possible, be within reach of a good-sized grounded appliance you can touch to discharge any static electricity that you may have acquired.

Step 3:

Open the PK-232 with the Phillips screwdriver by removing the six screws that hold the top cover in place. Then, carefully separate the top cover from the bottom chassis.

Step 4:

Make sure your unit is an AEA Model PK-232 MBX.

Your Data Controller must be a PK-232 MBX and should say so on the upper right-hand corner of the front panel. If your unit only says Model PK-232 on the front panel, then make sure that you have the MBX daughter board installed behind the THRESHOLD potentiometer as shown in Figure A.

If the serial number of your PK-232 does not begin with the letter "M" and is below 45,933 and you do not have a daughter board installed, then you must contact Timewave Technology Inc. to purchase one. These EPROMs will not work in a PK-232 below serial number 45,933 unless a daughter board is installed.

Step 5:

If your PK-232 MBX has a daughter board installed, refer to Figure A when continuing to the next step. If your PK-232 MBX does not have a daughter board installed, refer to Figure B while continuing to the next step.

Step 6:

Locate the EPROM chip sockets on the front left on your PK-232 MBX. If your PK-232 MBX has a daughter board installed, these will be sockets U1 and U3 as shown in Figure A. If your PK-232 MBX does not have a daughter board installed, these will be sockets U2 and U3 as shown in figure B.

Step 7:

If you have a daughter board, remove the EPROM chip from U1 and U3 only.

Note: Do NOT remove the ram chip in socket U5.

If the PK-232 MBX does not have a daughter board, remove the chip from U2 and U3.

Note: Don't worry if your PK-232 MBX does not have an EPROM installed in U3 on the daughterboard. Early version used only one EPROM.

Remove the IC chips from the PK-232 carefully by inserting the blade of a small straight-blade screwdriver between the EPROM and the socket, and gently lifting.

CAUTION: DO NOT TRY TO PRY THE SOCKET OFF THE BOARD. Be sure that you are working with the EPROM itself.

Step 8:

Install the new EPROM chip marked PK-232 MBX (Low) in the lower numbered socket that you just removed a chip from. *Make sure* that the semicircular notch is positioned towards the left of the board as shown in the drawings. Then install the EPROM chip marked PK-232 MBX (High) in the higher numbered socket, again making sure that the notch in the chip is positioned towards the left.

CAUTION: Installing an EPROM backwards **WILL** destroy the chip.

Step 9:

Replace the top cover of the PK-232 MBX with the six screws removed earlier.

This completes the installation of the PK-232 MBX firmware.

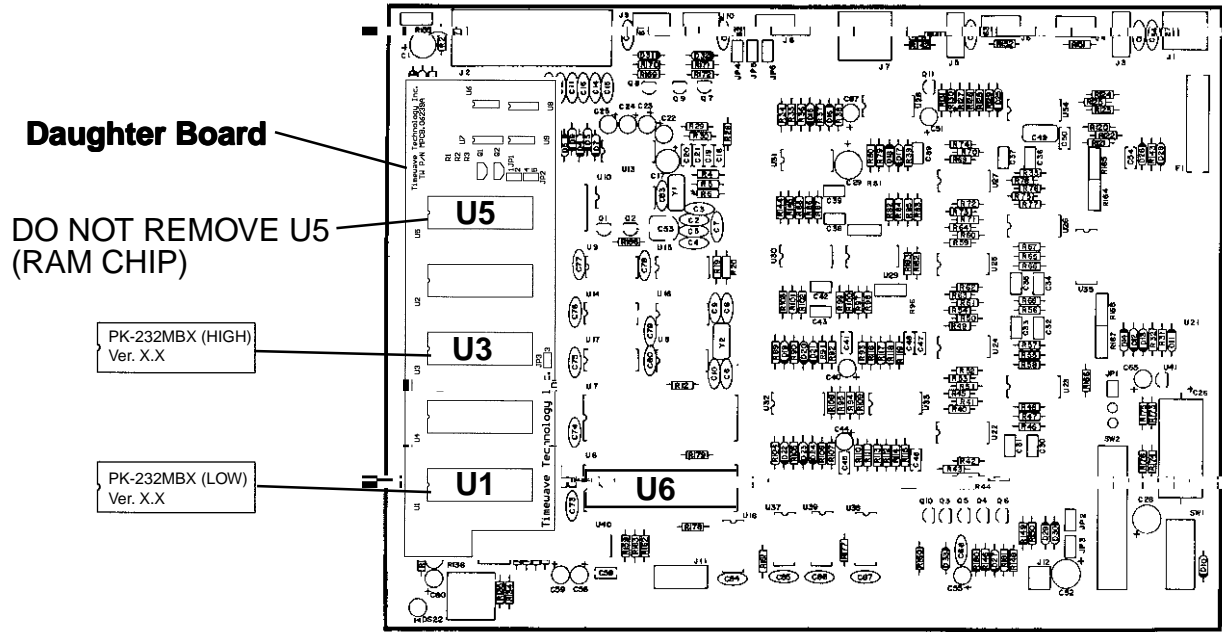

Figure A - PK-232 Main board with MBX daughter board installed

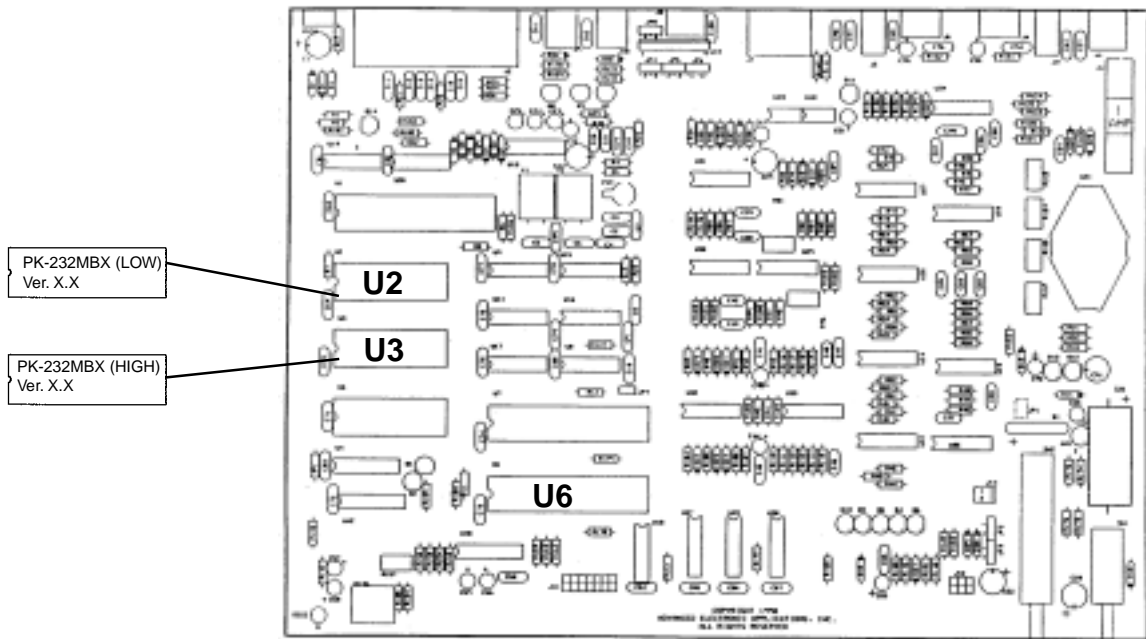

Figure B - PK-232MBX Main Board (No MBX daughter board necessary)

PLEASE READ THIS BEFORE INSTALLATION

INSTALLATION INSTRUCTIONS ADDENDUM

Before you start the installation on your PK-232/DSP upgrade, please inspect the DSP daughter-board. There is a 40-pin double header that plugs the daughter-board onto the PK-232 main circuit board. Take a minute and inspect this header and make sure the pins are not bent or badly aligned.

When you reach the point in the installation instructions asking you to “place the DSP daughter-board over the standoff” make very certain that the pins of the header is aligned exactly over the main board socket U-6.

After installing the DSP-board, double check the alignment of the daughter-board and socket on the main board. Make certain the first row of the header pins is in the first row of IC socket holes, not one row behind.

Replacement headers are \$8.00 each, plus shipping and handling.

73

Service Department

Timewave Technology

Visit our web page: <http://www.timewave.com>

Service@timewave.com

READ CAREFULLY BEFORE STARTING INSTALLATION

INSTALLATION INSTRUCTIONS PK-232/DSP BOARD

Thank you for purchasing the DSP upgrade for your PK-232MBX. The following instructions are to assist you with the installation of the DSP daughter-board. Please read these instructions completely before beginning this project.

PARTS LIST AND TOOLS

QTY PART DESCRIPTION

- 1 DSP daughter-board (A.06225)
- 1 Standoff

You will need the following tools to perform this Installation.

- #2 Phillips screwdriver
- Small flat blade screwdriver
- Needle nose pliers
- Small wire cutters or nippers
- 1/4" nut driver
- Solder iron or pencil (Do not use a solder gun)
- Solder

Please take a minute and make certain that the PK-232 you are upgrading is a PK-232MBX. If the unit you have was built as a PK-232MBX (Fig. B) skip to the next paragraph. If you are upgrading a PK-232 or PK-232 that has been upgraded to an MBX with an older wide board (Fig. A) you should replace that board with the narrow board supplied with this kit. The newer style narrow board is identified by the part number A.06239A. After installing the MBX upgrade, test the unit briefly before proceeding with the DSP upgrade.

Prepare a clean work area that is as static free as possible.

IMPORTANT NOTICE

Be sure to discharge any static build-up you may have incurred by touching a grounded appliance before proceeding.

- 1) Remove all cables and power from the PK-232.
- 2) Remove the top cover by removing the 6 screws from the side and back of the unit. Position the unit with the front toward you.
- 3) Determine if you have an old or new style board. Old boards have four 28 pin IC sockets running down the left side of the motherboard. New boards have three 28 pin IC sockets running down the

left side of the board (see figure B).

- 4) Locate and remove C-54 (located to the left of the fuse) using the wire cutters or nippers. (see fig. 3)
- 5) Using the flat blade of the screwdriver, carefully remove U6 from its socket and set aside. (Note how the chip is oriented in the socket, notch to the left as viewed from the front).

CAUTION: DO NOT TRY TO PRY THE SOCKET OFF THE BOARD. Be sure that you are working with the EPROM itself.

- 6) Using the Phillips screwdriver, remove the front center screw from the board and set the screw aside.
- 7) Install the standoff into the hole in the front where you just remove the screw. Secure the standoff with the 1/4" nut driver. **DO NOT OVER TIGHTEN.** This may damage the board or break the standoff.
- 8) Place the DSP board (part number A.063225) over the U6 socket. Be sure all 40 pins of the DSP board are aligned with the 40 holes of the socket U6. Press down firmly to seat the DSP board. Recheck the alignment of the pins into the socket.
- 9) Secure the DSP board with the screw set aside in step 5. **DO NOT OVER TIGHTEN.**
- 10) With the notch to the left, place U6 (removed in step 5) in the socket on the DSP board and After checking U6 to make sure all the pins are correctly aligned, press the chip firmly down. Check carefully that all pins are in the socket and not folded nor bent).
- 11) Starting with the left side wire on the DSP board. Attach this wire to R-186 (330 ohms Orange, Orange, Brown). Bend the wire in a "U" around lead of R-186, then press the ends of the "U" together using the needle nose pliers. If your PK-232 board is an "old" style board attach the wire to the left side of R-186 see fig 1. If your board is a "new" style board attaches the wire to the bottom (Toward the front) of R-186. Solder the connection. See fig. 2
- 12) The center wire is attached to the top lead of R-34 (10K ohms, Brown, Black, Orange) see fig. 4. Use the same "U" bend technique to attach the wire that you used on R-186. Solder.
- 13) T he right side wire is attached to the second pin from the top on the right side of the radio switch (SW2). Again make the "U" bend and attach the wire to the pin, then press the "U" together to make a strong mechanical attachment, Finish by soldering the connection. See fig 5. If the switch in yor PK-232 does not have external lugs the wire can be attached to the back pad of C-54 (C-54 was removed in step 4)
- 14) Replace the top cover and install the six screws removed in step 2.

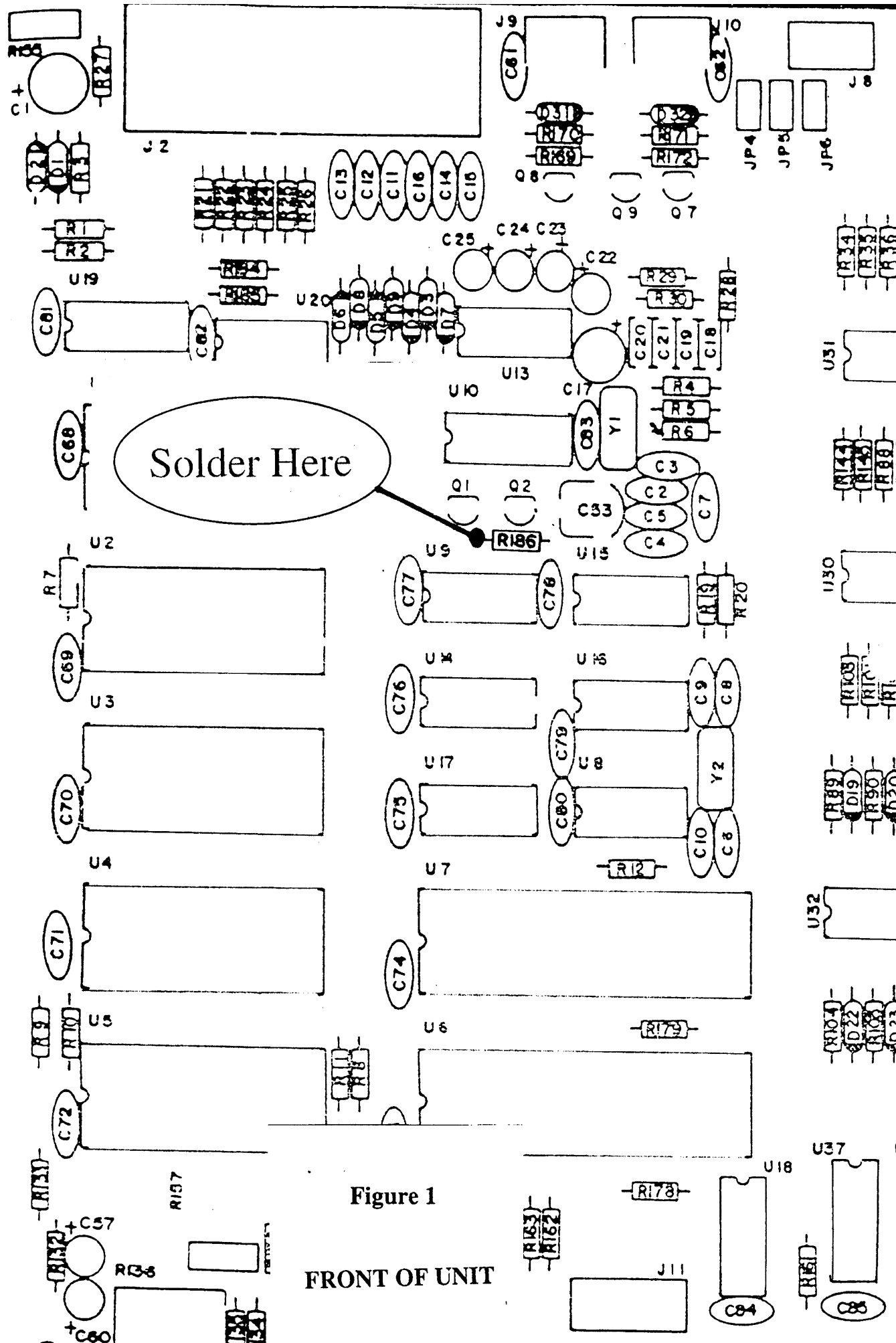

Figure 1

FRONT OF UNIT

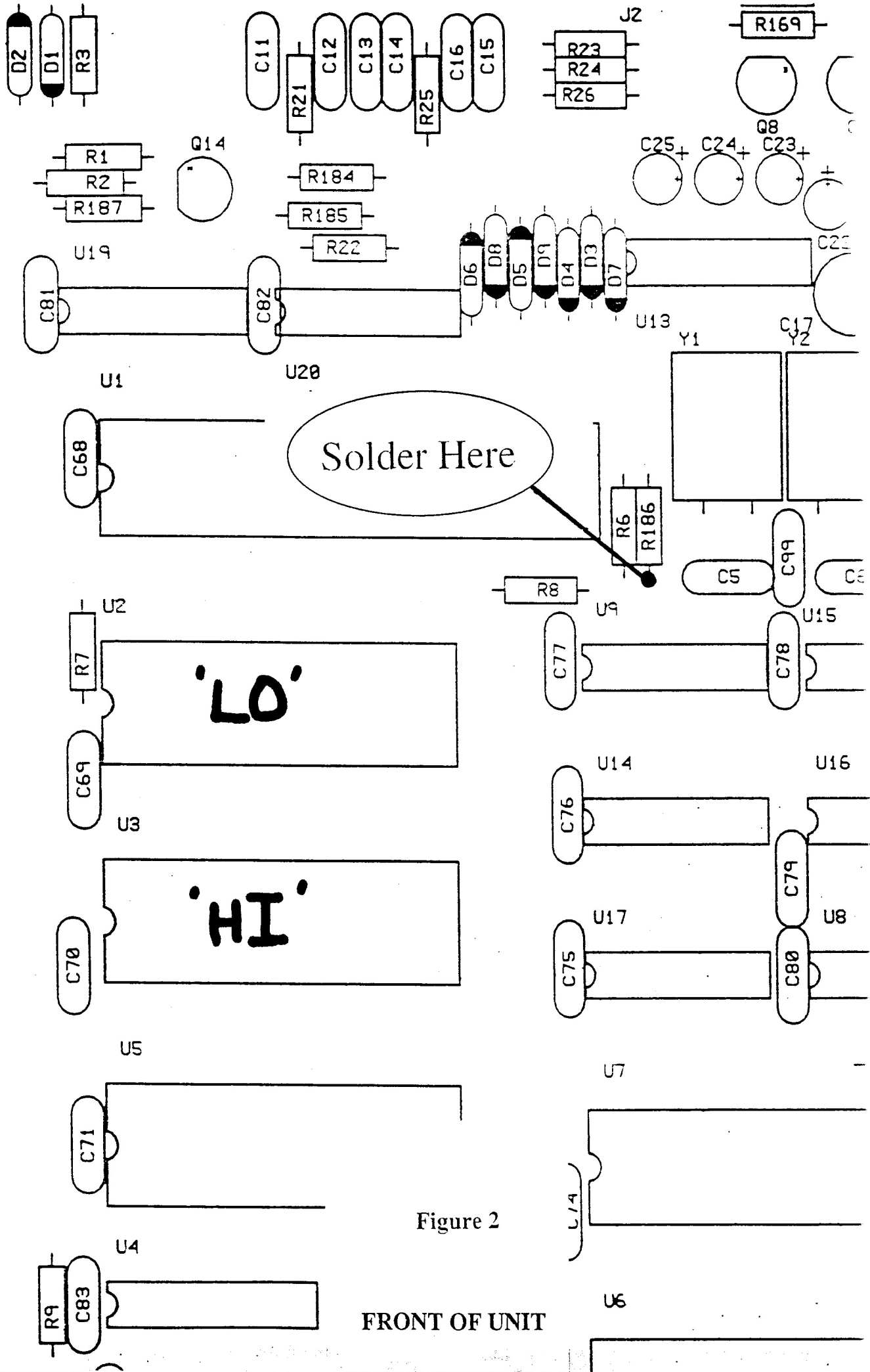

Figure 2

FRONT OF UNIT

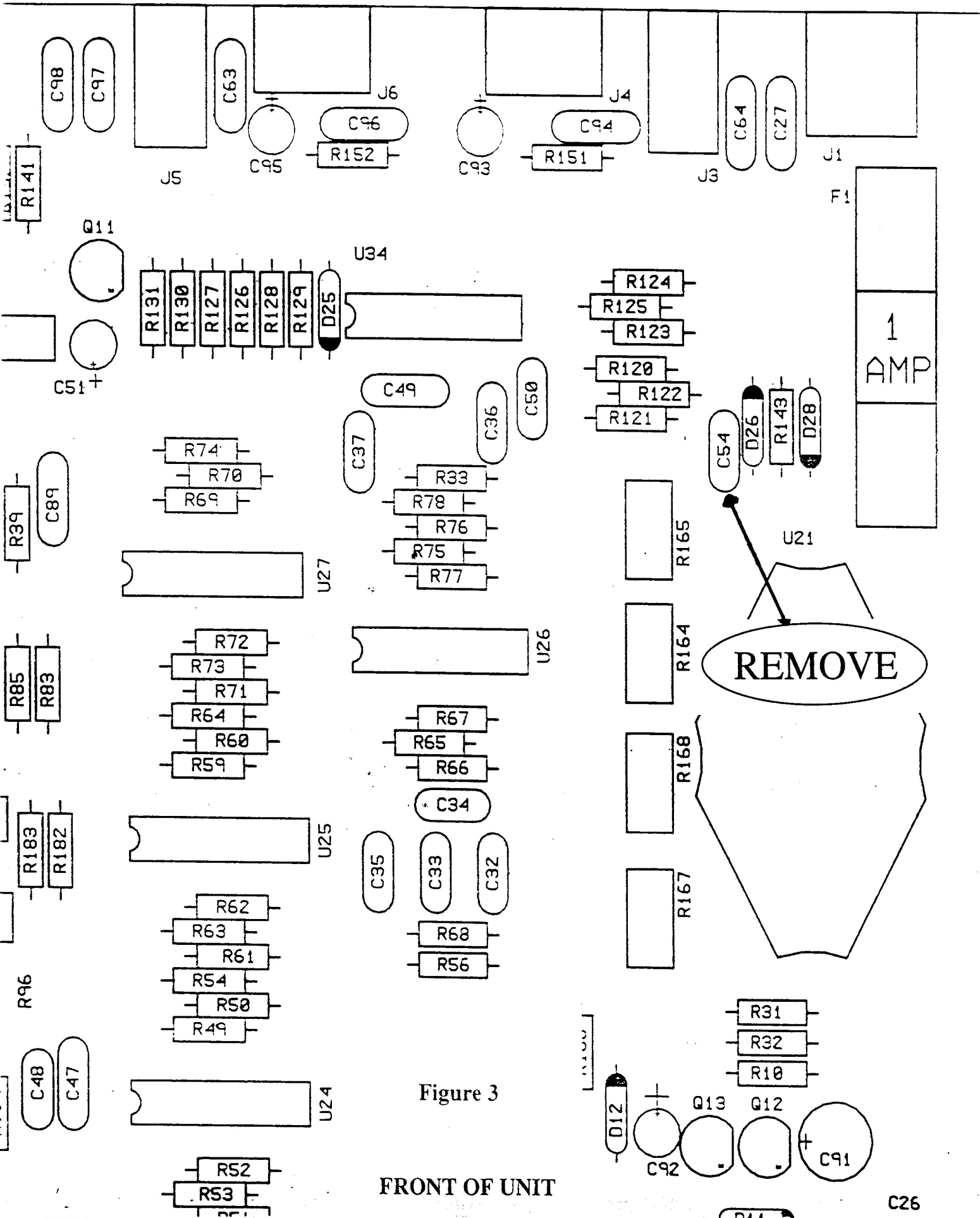

Figure 3

FRONT OF UNIT

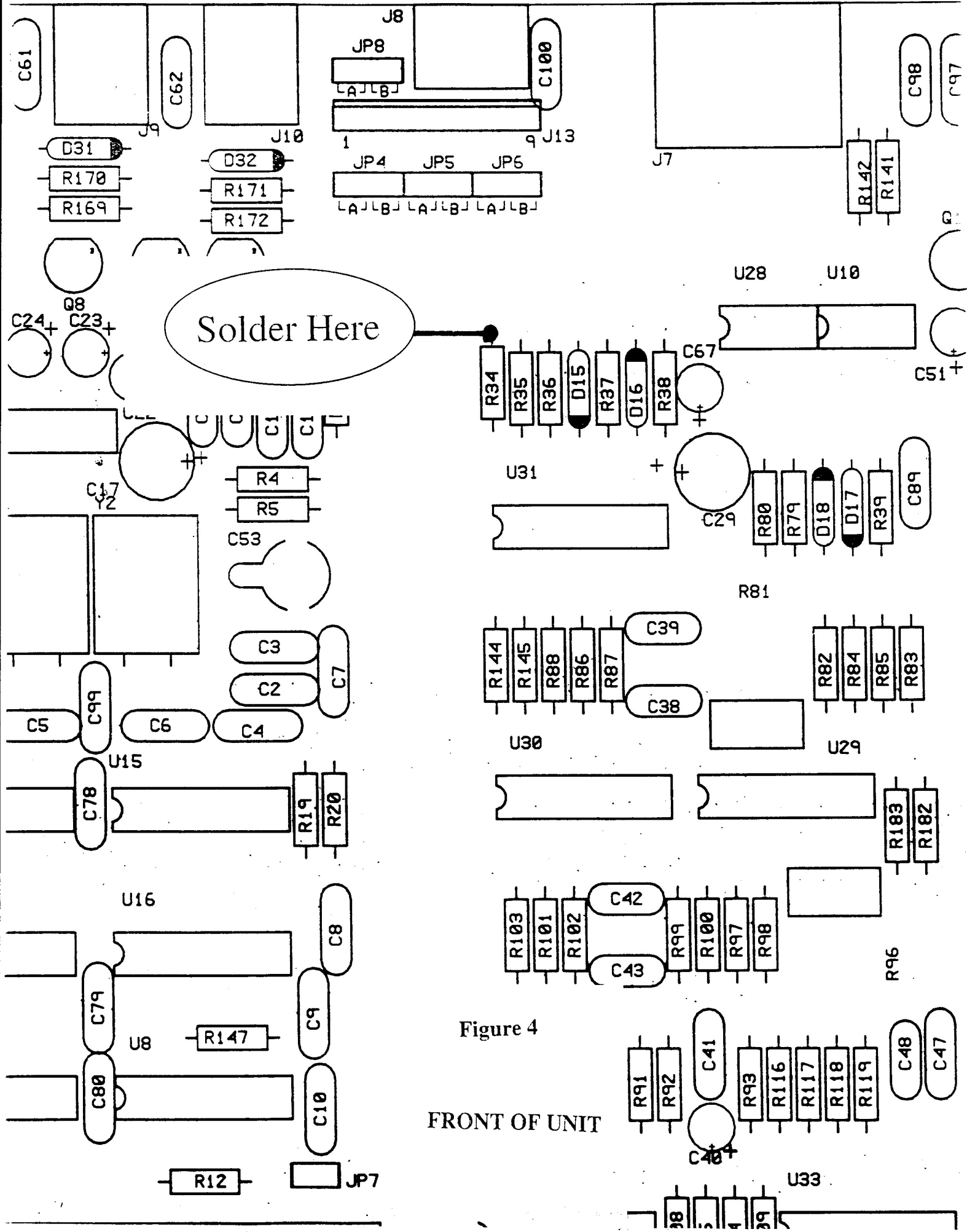

Figure 4

FRONT OF UNIT

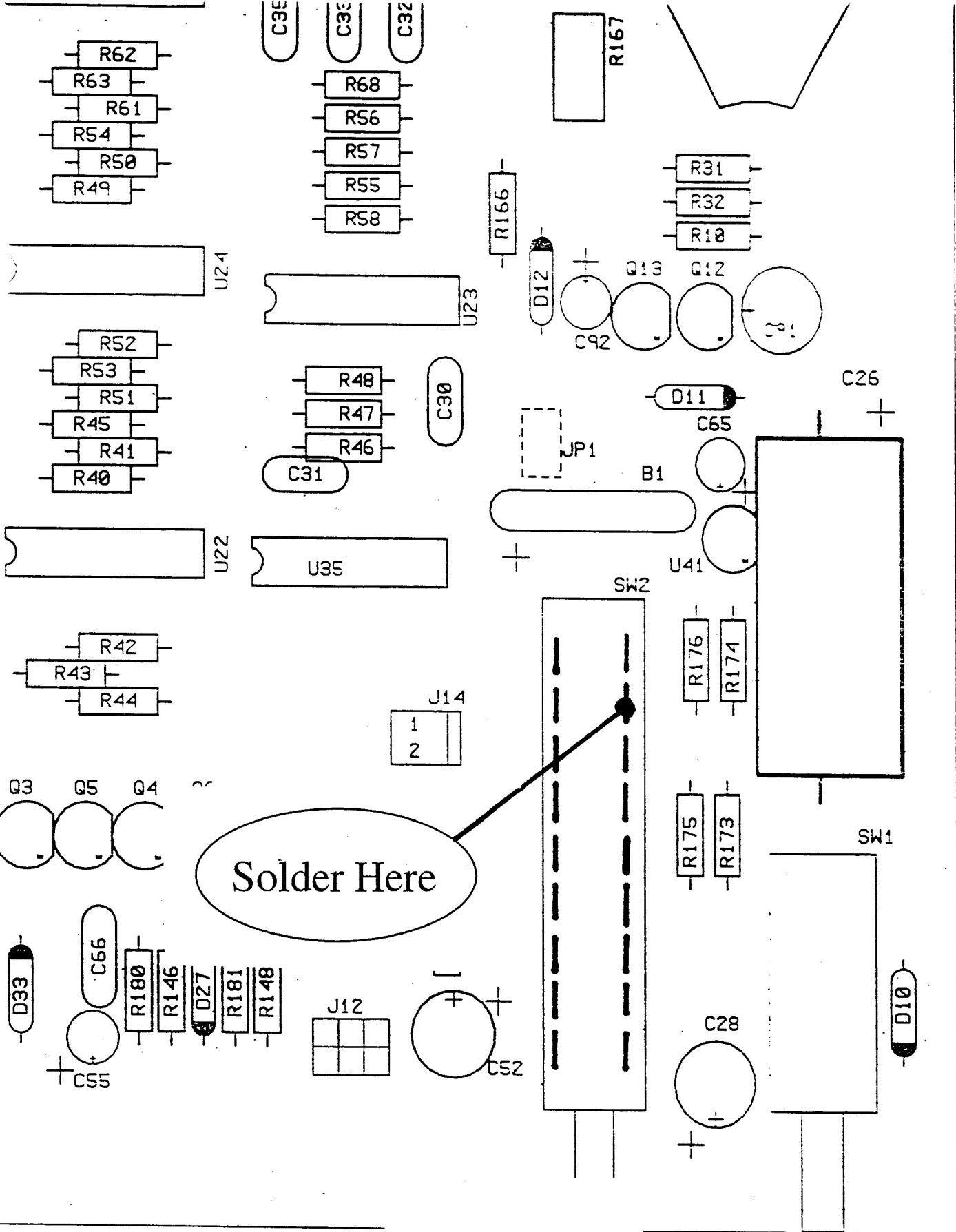
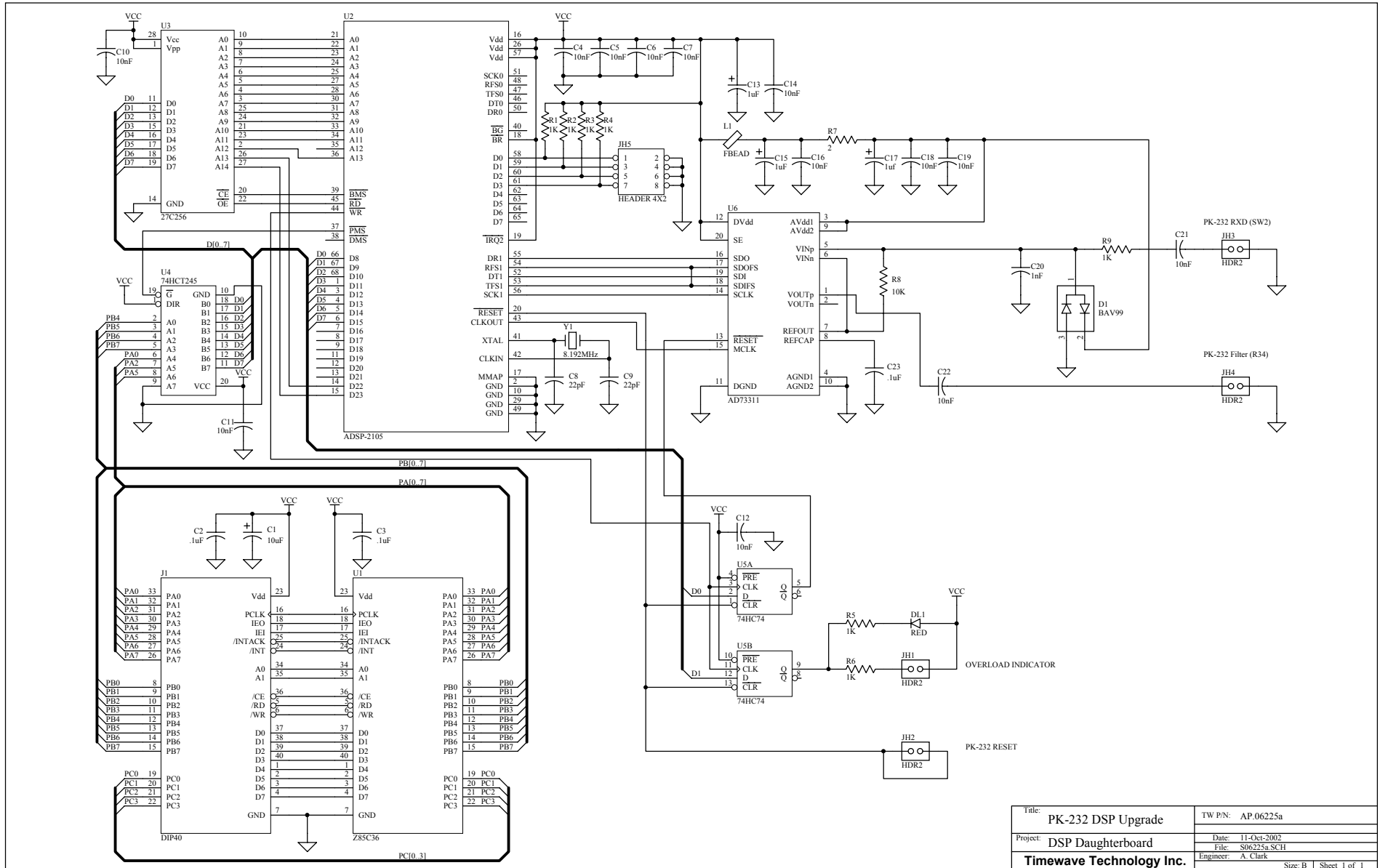

Figure 5

FRONT OF UNIT



Title:	PK-232 DSP Upgrade	TW P/N:	AP.06225a
Project:	DSP Daughterboard	Date:	11-Oct-2002
		File:	S06225a SCH1
		Engineer:	A. Clark
Timewave Technology Inc.		Size:	B
		Sheet:	1 of 1